

evolution®

www.evolutionpowertools.com

evoSAW³⁵⁵ evoSAW³⁸⁰

Original Instructions

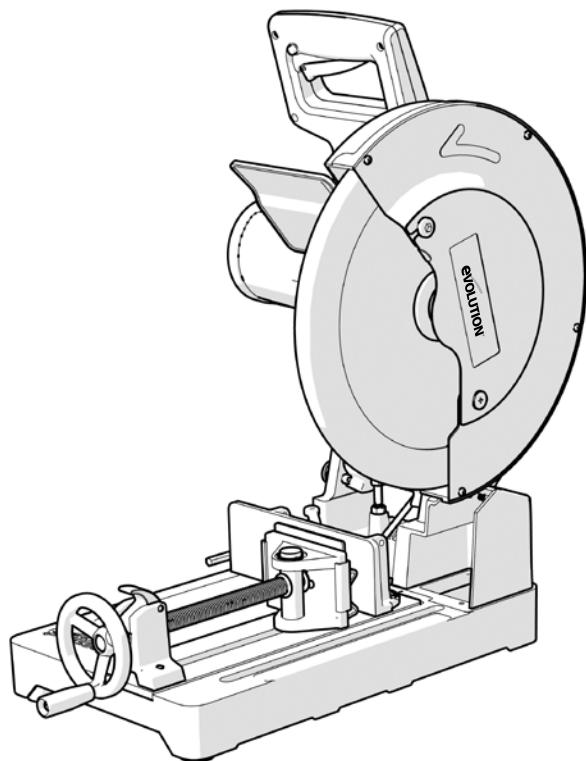

EN

ES

FR

evOLUTION[®]

ENGLISH

Original Instructions

EN

ES

FR

TABLE OF CONTENTS

English	Page 2
Español	Página 24
Français	Page 48
INTRODUCTION	
Guarantee	Page 5
Machine Specifications	Page 6
Vibration	Page 7
Labels and Symbols	Page 7
Intended use of this Power Tool	Page 8
Prohibited use of this Power Tool	Page 8
SAFETY PRECAUTIONS	
Electrical Safety	Page 9
Outdoor Use	Page 9
General Power Tool Safety Instructions	Page 9
Additional Safety Instructions	Page 11
GETTING STARTED	
Unpacking	Page 13
Machine Overview	Page 14
Assembly and Preparation	Page 15
Operating Instructions	Page 19
MAINTENANCE	
Environmental Protection	Page 21
DECLARATION OF CONFORMITY	Page 22

(1.2) THIS INSTRUCTION MANUAL WAS ORIGINALLY WRITTEN IN ENGLISH

(1.3) IMPORTANT

Please read these operating and safety instructions carefully and completely. For your own safety, if you are uncertain about any aspect of using this equipment please access the relevant Technical Helpline, the number of which can be found on the Evolution Power Tools website. We operate several Helplines throughout our worldwide organization, but Technical help is also available from your supplier.

WEB

www.evolutionpowertools.com

(1.4) Congratulations on your purchase of an Evolution Power Tools Machine. Please complete your product registration 'online' as explained in the A4 online guarantee registration leaflet included with this machine. You can also scan the QR code found on the A4 leaflet with a Smart Phone. This will enable you to validate your machine's guarantee period via Evolutions website by entering your details and thus ensure prompt service if ever needed. We sincerely thank you for selecting a product from Evolution Power Tools.

EVOLUTION LIMITED GUARANTEE

Evolution Power Tools reserves the right to make improvements and modifications to the product design without prior notice.

Please refer to the guarantee registration leaflet and/or the packaging for details of the terms and conditions of the guarantee.

(1.5) Evolution Power Tools will, within the guarantee period, and from the original date of purchase, repair or replace any goods found to be defective in materials or workmanship. This guarantee is void if the tool being returned has been used beyond the recommendations in the Instruction Manual or if the machine has been damaged by accident, neglect, or improper service.

This guarantee does not apply to machine's and / or components which have been altered, changed, or modified in any way, or subjected to use beyond recommended capacities and specifications. Electrical components are subject to respective manufacturers' warranties. All goods returned defective shall be returned prepaid freight to Evolution Power Tools. Evolution Power Tools reserves the right to optionally repair or replace it with the same or equivalent item.

There is no warranty – written or verbal – for consumable accessories such as (following list not exhaustive) blades, cutters, drills, chisels or paddles etc. In no event shall Evolution Power Tools be liable for loss or damage resulting directly or indirectly from the use of our merchandise or from any other cause. Evolution Power Tools is not liable for any costs incurred on such goods or consequential damages.

No officer, employee or agent of Evolution Power Tools is authorized to make oral representations of fitness or to waive any of the forgoing terms of sale and none shall be binding on Evolution Power Tools.

Questions relating to this limited guarantee should be directed to the company's head office, or call the appropriate Helpline number.

MACHINE SPECIFICATIONS
Motor UK (230-240V ~ 50 Hz)
Motor UK (110V ~ 50 Hz)
Motor USA (120V ~ 60 Hz)
Horsepower
Speed (No Load)
Weight

CUTTING CAPACITIES
Mild Steel Plate (Max Thickness)
Square Tube at 90° (Mild Steel)
Square Tube at 45° (Mild Steel)
Rectangle Tube at 90° (Mild Steel)
Rectangle Tube at 45° (Mild Steel)
Round Tube at 90° (Mild Steel)
Round Tube at 45° (Mild Steel)
Wood at 90° (Nominal Size)
Wood at 45° (Nominal Size)
Minimum Cut Off Piece Length

BLADE
Diameter
Bore / Arbor
Number of Teeth
Kerf

NOISE & VIBRATION DATA
Sound Pressure Level L_{pA}
Sound Power Level L_{WA}
Vibration Level

MODEL PART NUMBERS
United Kingdom
United States
Europe

evoSAW³⁵⁵

355mm (14") STEEL CUTTING CHOP SAW

METRIC	IMPERIAL
2200W	10A
1800W	16A
1800W	15A
2.4	2.4
1450min ⁻¹	1450rpm
28kg	62lb

METRIC	IMPERIAL
12mm	1/2"
120mm	4-3/4"
80mm	3-1/8"
95 x 180mm	3-3/4 x 7-1/8"
78 x 110mm	3 x 4-3/8"
130mm	5-1/8"
105mm	4-1/8"
89 x 184mm	4 x 8"
64 x 89mm	3 x 4"
8mm	5/16"

METRIC	IMPERIAL
355mm	14"
25mm	1"
66	66
1.7mm	.094"

108 dB (A) K = 3 dB(A)
121 dB (A) K = 3 dB(A)
1.39 m/s ² K = 0.5 m/s ²

230V: 080-0001 110V: 080-0002
080-0002
080-0003

evoSAW³⁸⁰

380mm (15") STEEL CUTTING CHOP SAW*

METRIC	IMPERIAL
2200W	10A
1800W	16A
1800W	15A
2.4	2.4
1450min ⁻¹	1450rpm
28kg	62lb

METRIC	IMPERIAL
12mm	1/2"
127mm	5"
90mm	3-1/2"
95 x 200mm	3-3/4 x 7-7/8"
78 x 110mm	3 x 4-3/8"
150mm	5-7/8"
127mm	5"
89 x 184mm	4 x 8"
89 x 89mm	4 x 4"
8mm	5/16"

METRIC	IMPERIAL
380mm	15"
25mm	1"
70	70
1.7mm	.094"

108 dB (A) K = 3 dB(A)
121 dB (A) K = 3 dB(A)
1.39 m/s ² K = 0.5 m/s ²

230V: 080-0007 110V: 080-0008
080-0004
080-0009

*Supplied with a 355mm (14") Steel blade. To achieve maximum capacities stated, fit with a 380mm (15") industrial saw blade.

(1.6) Note: The vibration measurement was made under standard conditions in accordance with: BS EN 61029-1:2009.

The declared vibration total value has been measured in accordance with a standard test method and may be used for comparing one tool with another.

The declared vibration total value may also be used in a preliminary assessment of exposure.

(1.7) VIBRATION

WARNING: When using this machine the operator can be exposed to high levels of vibration transmitted to the hand and arm.

It is possible that the operator could develop "Vibration white finger disease" (Raynaud syndrome). This condition can reduce the sensitivity of the hand to temperature as well as producing general numbness.

Prolonged or regular users of this machine should monitor the condition of their hands and fingers closely. If any of the symptoms become evident, seek immediate medical advice.

- The measurement and assessment of human exposure to hand-transmitted vibration in the workplace is given in: BS EN ISO 5349-1:2001 and BS EN ISO 5349-2:2002.
- Many factors can influence the actual vibration level during operation e.g. the work surfaces condition and orientation and the type and condition of the machine being used. Before each use, such factors should be assessed, and where possible appropriate working practices adopted. Managing these factors can help reduce the effects of vibration:

Handling

- Handle the machine with care, allowing the machine to do the work.
- Avoid using excessive physical effort on any of the machine's controls.
- Consider your security and stability, and the orientation of the machine during use.

Work Surface

- Consider the work surface material; its condition, density, strength, rigidity and orientation.

WARNING: The vibration emission during actual use of the power tool can differ from the declared total value depending on the ways in which the tool is used.









The need to identify safety measures and to protect the operator are based on an estimation of exposure in the actual conditions of use (taking account all parts of the operating cycle, such as the times the tool is switched off, when it is running idle, in addition to trigger time).

(1.8) LABELS & SYMBOLS

WARNING: Do not operate this machine if warning and/or instruction labels are missing or damaged. Contact Evolution Power Tools for replacement labels.

Note: All or some of the following symbols may appear in the manual or on the product.

(1.9)

Symbol	Description
V	Volts
A	Amperes
Hz	Hertz
Min ⁻¹	Speed
~	Alternating Current
no	No Load Speed
	Wear Safety Goggles
	Wear Ear Protection
	Wear Dust Protection
	Read Instructions
	CE certification
	CSA certification
	Waste electrical and electronic equipment
	Warning

(1.10) INTENDED USE OF THIS POWER TOOL

WARNING: This product is a Hand Operated Chop Saw and has been designed to be used with special Evolution blades. Only use accessories designed for use in this machine and/or those recommended specifically by Evolution Power Tools Ltd.

When fitted with an appropriate blade this machine can be used to cut:

Mild Steel
Aluminium
Wood
Stainless Steel

(1.11) PROHIBITED USE OF THIS POWER TOOL

WARNING: This product is a Hand Operated Chop Saw and must only be used as such. It must not be modified in any way, or used to power any other equipment or drive any other accessories other than those mentioned in this Instruction Manual.

(1.13) WARNING: This machine is not intended for use by persons (including children) with reduced physical, sensory or mental capabilities, or lack of experience and knowledge, unless they have been given supervision or instruction concerning the safe use of the machine by a person responsible for their safety and who is competent in its safe use.

Children should be supervised to ensure that they do not have access to, and are not allowed to play with, this machine.

(1.14) ELECTRICAL SAFETY

This machine is fitted with the correct moulded plug and mains lead for the designated market. If the supply cord is damaged, it must be replaced by a special cord or assembly available from the manufacturers or its service agent.

(1.15) OUTDOOR USE

WARNING: For your protection if this tool is to be used outdoors it should not be exposed to rain, or used in damp locations. Do not place the tool on damp surfaces. Use a clean, dry workbench if available. For added protection use a residual current device (R.C.D.) that will interrupt the supply if the leakage current to earth exceeds 30mA for 30ms. Always check the operation of the residual current device (R.C.D.) before using the machine.

If an extension cable is required it must be a suitable type for use outdoors and so labelled. The manufacturer's instructions should be followed when using an extension cable.

(2.1) POWER TOOL GENERAL SAFETY INSTRUCTIONS

(These General Power Tool Safety Instructions are as specified in BS EN 60745-1:2009 & EN 61029-1:2009).

WARNING: Read all safety warnings and instructions. Failure to follow the warnings and instructions may result in electric shock, fire and/ or serious injury.

Save all warnings and instructions for future reference. The term "power tool" in the warnings refers to your mains-operated (corded) power tool or battery-operated (cordless) power tool.

(2.2) 1) General Power Tool Safety Warnings [Work area safety]

- a) Keep work area clean and well lit.** Cluttered or dark areas invite accidents.
- b) Do not operate power tools in explosive atmospheres, such as in the presence of flammable liquids, gases or dust.** Power tools create sparks which may ignite the dust or fumes.
- c) Keep children and bystanders away while operating power tool.** Distractions can cause you to lose control.

(2.3) 2) General Power Tool Safety Warnings [Electrical Safety]

- a) Power tool plugs must match the outlet.** Never modify the plug in any way. Do not use any adapter plugs with earthed (grounded) power tools. Unmodified plugs and matching outlets will reduce the risk of electric shock.
- b) Avoid body contact with earthed or grounded surfaces, such as pipes, radiators, ranges and refrigerators.** There is an increased risk of electric shock if your body is earthed or grounded.
- c) Do not expose power tools to rain or wet conditions.** Water entering a power tool will increase the risk of electric shock.
- d) Do not abuse the cord. Never use the cord for carrying, pulling or unplugging the power tool.** Keep cord away from heat, oil, sharp edges or moving parts. Damaged or entangled cords increase the risk of electric shock.
- e) When operating a power tool outdoors, use an extension cord suitable for outdoor use.** Use of a cord suitable for outdoor use reduces the risk of electric shock.
- f) If operating a power tool in a damp location is unavoidable, use a residual current device (RCD) protected supply.** Use of an RCD reduces the risk of electric shock.

EN

ES

FR

(2.4) 3) General Power Tool Safety Warnings [Personal Safety].

a) Stay alert, watch what you are doing and use common sense when operating a power tool. Do not use a power tool while you are tired or under the influence of drugs, alcohol or medication. A moment of inattention while operating power tools may result in serious personal injury.

b) Use personal protective equipment. Always wear eye protection. Protective equipment such as dust masks, non-skid safety shoes, hard hat or hearing protection used for appropriate conditions will reduce personal injuries.

c) Prevent unintentional starting. Ensure the switch is in the off-position before connecting to power source and or battery pack, picking up or carrying the tool. Carrying power tools with your finger on the switch or energising the power tools that have the switch on invites accidents.

d) Remove any adjusting key or wrench before turning the power tool on. A wrench or key left attached to a rotating part of a power tool may result in personal injury.

e) Do not overreach. Keep proper footing and balance at all times. This enables better control of the power tool in unexpected situations.

f) Dress properly. Do not wear loose clothing or jewellery. Keep your hair, clothing and gloves away from moving parts. Loose clothes, jewellery or long hair can be caught in moving parts.

g) If devices are provided for the connection of dust extraction and collection facilities, ensure that these are connected and properly used. Use of dust collection can reduce dust-related hazards.

(2.5) 4) General Power Tool Safety Warnings [Power tool use and care].

a) Do not force the power tool. Use the correct power tool for your application. The correct power tool will do the job better and safer at a rate for which it was designed.

b) Do not use the power tool if the switch does not turn it on or off. Any power tool that cannot be controlled with the switch is dangerous and must be repaired.

c) Disconnect the power tool from the power source and/or battery pack from the power tool before making any adjustments, changing accessories, or storing power tools. Such preventative safety measures reduce the risk of starting the power tool accidentally.

d) Store idle power tools out of the reach of children and do not allow persons unfamiliar with the power tool or these instructions to operate the power tool. Power tools are dangerous in the hands of untrained users.

e) Maintain power tools. Check for misalignment or binding of moving parts, breakage of moving parts and any other condition that may affect the power tools operation. If damaged, have the power tool repaired before use. Many accidents are caused by poorly maintained power tools.

f) Keep cutting tools sharp and clean. Properly maintained cutting tools with sharp cutting edges are less likely to bind and are easier to control.

g) Use the power tool, accessories and tool bits etc. in accordance with these instructions, taking into account the working conditions and the work to be performed. Use of the power tool for operations different from those intended could result in a hazardous situation.

(2.6) 5) General Power Tool Safety Warnings [Service]

a) **Have your power tool serviced by a qualified repair person using only identical replacement parts.** This will ensure that the safety of the power tool is maintained.

(2.7) HEALTH ADVICE

WARNING: When using this machine, dust particles may be produced. In some instances, depending on the materials you are working with, this dust can be particularly harmful. If you suspect that paint on the surface of material you wish to cut contains lead, seek professional advice. Lead based paints should only be removed by a professional and you should not attempt to remove it yourself. Once the dust has been deposited on surfaces, hand to mouth contact can result in the ingestion of lead. Exposure to even low levels of lead can cause irreversible brain and nervous system damage. The young and unborn children are particularly vulnerable. You are advised to consider the risks associated with the materials you are working with and to reduce the risk of exposure. As some materials can produce dust that may be hazardous to your health, we recommend the use of an approved face mask with replaceable filters when using this machine.

You should always:

- Work in a well-ventilated area.
- Work with approved safety equipment, such as dust masks that are specially designed to filter microscopic particles.

(2.8)

WARNING: The operation of any power tool can result in foreign objects being thrown towards your eyes, which could result in severe eye damage. Before beginning power tool operation, always wear safety goggles or safety glasses with side shield or a full face shield where necessary.

(3.0) ADDITIONAL SAFETY INSTRUCTIONS

(3.1)

a) DANGER: Keep hands away from cutting area and the blade. Keep your second hand on auxiliary handle, or motor housing. If both hands are holding the saw, they cannot be cut by the blade.

b) Do not reach underneath the workpiece. The guard cannot protect you from the blade below the workpiece.

c) Adjust the cutting depth to the thickness of the workpiece. Less than a full tooth of the blade teeth should be visible below the workpiece.

d) Never hold piece being cut in your hands or across your leg. Secure the workpiece to a stable platform. It is important to support the work properly to minimize body exposure, blade binding, or loss of control.

e) Hold power tool by insulated gripping surfaces when performing an operation where the cutting tool may contact hidden wiring or its own cord. Contact with a "live" wire will also make exposed metal parts of the power tool "live" and shock the operator.

f) When ripping always use a rip fence or straight edge guide. This improves the accuracy of cut and reduces the chance of blade binding.

g) Always use blades with correct size and shape (diamond versus round) of arbor holes. Blades that do not match the mounting hardware of the saw will run eccentrically, causing loss of control.

h) Never use damaged or incorrect blade washers or bolt. The blade washers and bolt were specially designed for your saw, for optimum performance and safety of operation.

i) Do not use High Speed Steel (HSS) saw blades.

j) Inspect the machine and the blade before each use. Do not use deformed, cracked, worn or otherwise damaged blades.

EN

ES

FR

k) Never use the saw without the original guard protection system. Do not lock the moving guard in the open position. Ensure that the guard operates freely without jamming.

l) Only use blades that comply with the characteristics specified in this manual.

Before using accessories, always compare the maximum allowed RPM of the accessory with the RPM of the machine.

(3.2)

Causes and operator prevention of kickback:

Kickback is a sudden reaction to a pinched, bound or misaligned saw blade, causing an uncontrolled saw to lift up and out of the workpiece toward the operator:

1. When the blade is pinched or bound tightly by the kerf closing down, the blade stalls and the motor reaction drives the unit rapidly back toward the operator.

2. If the blade becomes twisted or misaligned in the cut, the teeth at the back edge of the blade can dig into the top surface of the workpiece causing the blade to climb out of the kerf and jump back towards the operator.

(3.3)

Kickback is the result of saw misuse and/or incorrect operating procedures or conditions and can be avoided by taking proper precautions as given below.

a) Maintain a firm grip with both hands on the saw and position your arms to resist kickback forces. Position your body to either side of the blade, but not in line with the blade. Kickback could cause the saw to jump backwards, but kickback forces can be controlled by the operator, if proper precautions are taken.

b) If the blades are binding, or when interrupting a cut for any reason, release the trigger and hold the saw motionless in the material until the blades come to a complete stop. Never attempt to remove the saw from the work or pull the saw backward while the blades are in motion or kickback may occur. Investigate and take corrective actions to eliminate the cause of blade binding.

c) When restarting a saw in the workpiece, centre the saw blade in the kerf and check that saw teeth are not engaged into the material. If saw blade is binding, it may walk up or kickback from the workpiece as the saw is restarted.

d) Support large panels to minimise the risk of blade pinching and kickback. Large panels tend to sag under their own weight. Supports must be placed under the panel on both sides, near the line of cut and near the edge of the panel.

e) Blade depth and bevel adjusting locking levers must be tight and secure before making a cut. If the blade adjustment shifts while cutting it may cause binding and kickback.

f) Do not use dull or damaged blades.

Unsharpened or improperly set blades produce a narrow kerf causing excessive friction, blade binding and kickback.

g) Use extra caution when making a “plunge cut” into existing walls or other blind areas. The protruding blade may cut objects that can cause kickback.

h) Check lower guard for proper closing before each use. Do not operate the saw if lower guard does not move freely and close instantly. Never clamp or tie the lower guard into the open position. If saw is accidentally dropped, lower guard may be bent. Raise the lower guard with the retracting handle (if equipped) and make sure it moves freely and does not touch the blade or any other part, in all angles and depths of cut.

i) Check the operation of the lower guard spring. If the guard and the spring are not operating properly, they must be serviced before use. Lower guard may operate sluggishly due to damaged parts, gummy deposits, or a build-up of debris.

j) Lower guard may be retracted manually only for special cuts such as “plunge cuts” and “compound cuts.” Raise lower guard by retracting handle and as soon as blade enters the material, the lower guard must be released. For all other sawing, the lower guard should operate automatically.

k) Always observe that the lower guard is covering the blade before placing saw down on a bench or the floor. An unprotected, coasting blade will cause the saw to walk backwards, cutting whatever is in its path. Be aware of the time it takes for the blade to stop after switch is released.

(3.4)

WARNING: If any parts are missing, do not operate your machine until the missing parts are replaced. Failure to follow this rule could result in serious personal injury.

(4.1)

GETTING STARTED - UNPACKING

Caution: This packaging contains sharp objects. Take care when unpacking. Remove the machine, together with the accessories supplied from the packaging. Check carefully to ensure that the machine is in good condition and account for all the accessories listed in this manual. Also make sure that all the accessories are complete. If any parts are found to be missing, the machine and its accessories should be returned together in their original packaging to the retailer.

Do not throw the packaging away; keep it safe throughout the guarantee period. Dispose of the packaging in an environmentally responsible manner. Recycle if possible.

Do not let children play with empty plastic bags due to the risk of suffocation.

(4.2)

ITEMS SUPPLIED

Description	Quantity
Instruction Manual	1
Steel Cutting Blade	1
Hex Key 8mm (Blade Change)	1
'V' Clamp Jaw	1

(4.3)

ADDITIONAL ACCESSORIES

In addition to the standard items supplied with this machine the following accessories are also available from the Evolution online shop at www.evolutionpowertools.com or from your local retailer.

(4.4)

Description	Part No
Material specific cutting blades (use only Evolution Blades or Evolution approved blades with this machine)	Specific to blade type

MACHINE OVERVIEW

A parts diagram can be downloaded from www.evolutionpowertools.com.

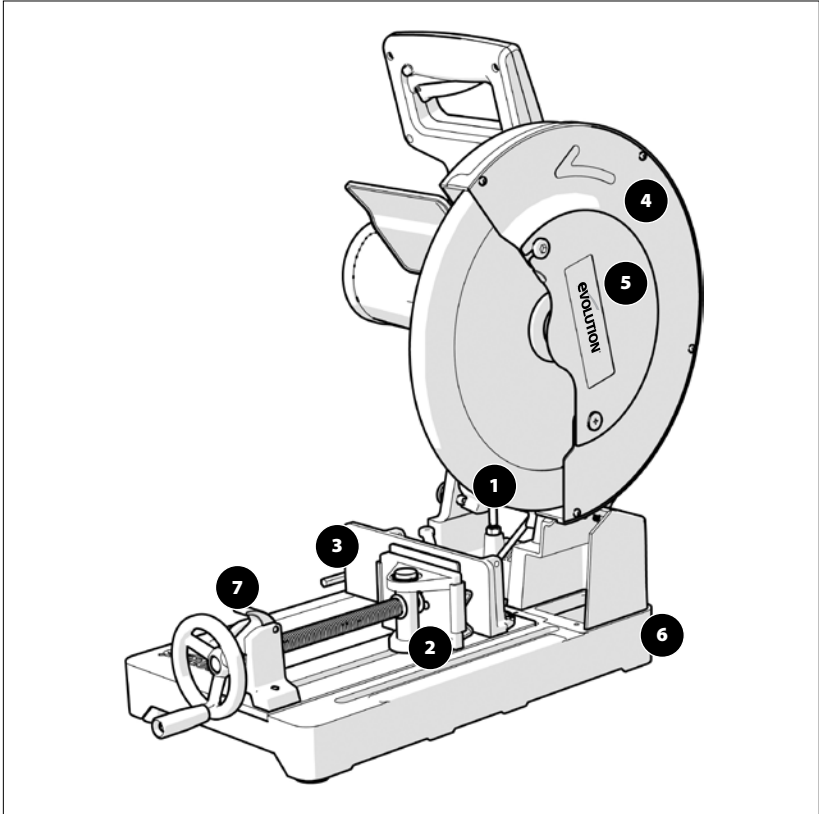

- | | |
|---------------------------------|------------------------------|
| 1. Lower Blade Guard | 5. Arbor Guard |
| 2. Front Swivelling Vise Jaw | 6. Chip Collection Tray |
| 3. Repositionable Rear Vise Jaw | 7. Quick Release 'Split Nut' |
| 4. Upper Blade Guard | |

(>5.5)

GETTING STARTED - PREPARATION**RELEASING the CUTTING HEAD**

The cutting head will automatically rise to the upper position once it is released from the locked down position.

To Release the cutting head from the Locked Down position: (5.5<)

- Gently press down on the cutting handle.
- Pull out the head latching pin and lock in the outer position. **(Fig. 1)** Allow the cutting head to rise to its upper position.

If Release is Difficult:

- Gently rock the cutting head up and down.
- Pull the latching pin fully out and turn 1/4 of a turn to lock in the outer position.

Note: We recommend that when the machine is not in use the cutting head is locked in its down position with the latching pin fully engaged in its socket.

(>5.1)

INSTALLING or REMOVING a BLADE

WARNING: Only use genuine Evolution blades, or Evolution approved blades which are designed for this machine. Ensure that the maximum recommended blade speed of the blade is compatible with the machine.

WARNING: Only perform this operation with the machine disconnected from the power supply.

Note: It is recommended that the operator considers wearing protective gloves when handling the blade during installation or when changing the machine's blade. (< 5.1)

(5.6)

Removing a Blade:

- Ensure that the cutting head is in its upper position.
- Loosen the fastener screw securing the arbor guard and rotate the guard upwards to reveal the machine's arbor. **(Fig. 2)**
- Engage the arbor lock by pressing the arbor lock button. **(Fig. 3)**
- Use the supplied hex key to loosen the arbor screw. **(Fig. 4)**

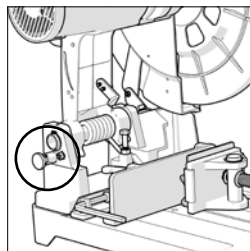
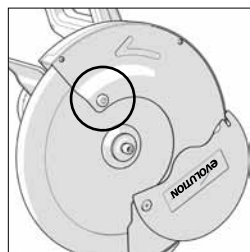
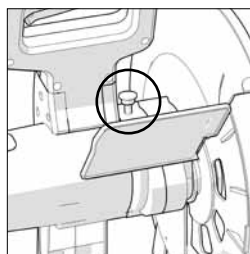
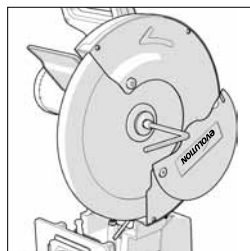
**Fig. 1****Fig. 2****Fig. 3****Fig. 4**

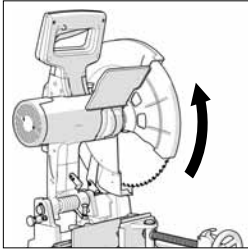

Fig. 5

Note: The arbor screw has a right hand thread. Turn clockwise to tighten. Turn counterclockwise to loosen.

- Remove the arbor screw, washer and outer blade flange and store safely for future installation.
- Retract the lower blade guard up into the upper blade guard by rotating it by hand. **(Fig. 5)**
- Remove the blade, leaving the inner blade flange in its service position.

(5.7)

Installing a Blade:

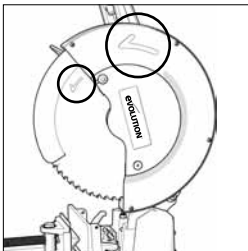

Fig. 6

- Ensure that all components are free from dirt and debris.
- Install the blade onto the inner blade flange and arbor, ensuring that the direction and rotation arrow on the blade matches the direction of arrow rotation found on the machine's upper blade guard. **(Fig. 6)**
- Reinstall the outer blade flange, washer and arbor screw.
- Lock the arbor by pressing the arbor lock button.
- Tighten the arbor screw using the 8mm hex key.
- Return the arbor guard to its service position and tighten the cross head screw.
- Check that the arbor lock has been released by rotating the blade by hand.
- Ensure that the hex key is removed from the arbor screw and is safely stored for future use.
- Check the installation, and particularly the operation of the retractable lower blade guards by lowering and raising the cutting head a few times.

(5.8)

WARNING: After installing a new blade, always run the machine, without load, for a couple of minutes. Stand away from the blade. If the blade were to contain an undetected flaw, it could shatter during this trial run.

(5.9) CUTTING HEAD TRAVEL

Cutting Head Downward Travel Adjustment

To prevent the blade from contacting any part of the machine's metal base the downward travel of the cutting head can be adjusted.

Lower the cutting head and check for any blade contact with the machine's base.

If the downward travel of the cutting head needs to be adjusted:

- Loosen the locknut on the downward travel stop screw. (**Fig. 7a**)
- Turn the adjusting screw (**Fig. 7b**) out (counter-clockwise) to decrease the downwards travel of the cutting head.
- Turn the adjusting screw in (clockwise) to increase the downwards travel of the cutting head.
- Tighten the adjustment screw locknut when satisfactory downward travel of the cutting head is achieved.

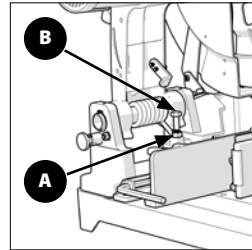

Fig. 7

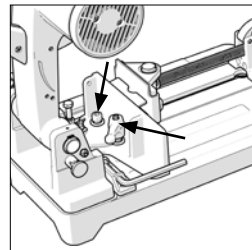

Fig. 8

(5.10) CUTTING ANGLE ADJUSTMENT

Note: The rear vise jaw can be turned through 45°.

The rear vise jaw is factory set at 0° (at 90° to the blade) so that the blade cuts squarely across material positioned in the vise. For angled cuts, the rear vise jaw can be swung through (up to) 45°, with a protractor scale being included on the vise jaw for ease and accuracy of setting. (>5.10)

To angle the rear vise jaw:

- Loosen the M10 socket headed screw and the lever handled locking screw. (**Fig. 8**)
- Turn the rear vise jaw to the required angle.
- Tighten the socket headed screw securely using the supplied hex key and tighten the lever handled locking screw.

Note: The lever handle locking screw has a spring loaded repositionable lever. Repositioning of the lever may be necessary to ensure that the locking screw can be tightened sufficiently when the rear vise jaw is angled. To reposition the lever on the screw, pull the lever upwards and rotate the lever to a convenient position (one that allows the screw to be tightened) release the lever and tighten the screw. The front vise jaw will automatically compensate for any set angle of the rear jaw, or to accommodate irregular shaped workpieces.

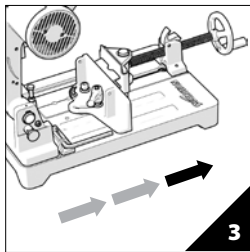
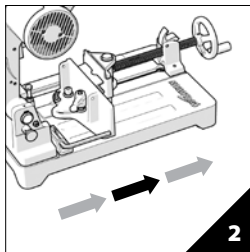
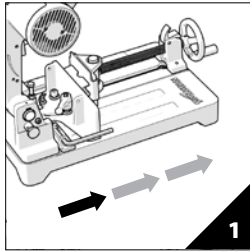

Fig. 9

REPOSITIONING THE REAR VISE JAW

The rear vise jaw can be removed from the machine's base and repositioned. **(Fig.9)**

To reposition:

- Remove the M10 socket headed screw and the lever handled locking screw and all washers that secure the rear vise jaw to the machine's base.
- To remove the lever handled locking screw, pull the lever upwards and hold against the spring while unscrewing the locking screw from its service position using a flat bladed screwdriver.
- Reposition the rear vise jaw; there are three (3) possible positions available because of the six (6) threaded holes in the machine's base.
- Replace lever handled locking screw and the socket headed screw into their new service positions. Ensure that all standard and locking washers are correctly positioned.

Repositioning the rear vise jaw to the rear-most position will enable wider pieces of material to be cut than is possible with the rear vise jaw in either of the more forward positions.

'V' Clamp Jaw (if supplied)

The 'V' Clamp Jaw slips over the moving front vise jaw **(Fig. 10)** It should be used when cutting round material as it provides greater clamping security. It may also be used with square section material to position such material diagonally in the vise.

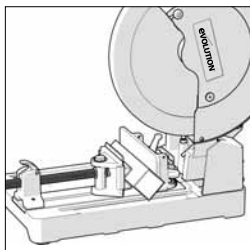

Fig. 10

QUICK VISE ADJUSTMENT MECHANISM (NORTH AMERICAN MARKET ONLY)

For speed and convenience, the vise operating mechanism is equipped with a 'split nut'. Using this enables rapid adjustment of the front vise jaw.

- Lift the 'split nut'. (Fig. 11a)
- Slide the front jaw to the required position.
- Return the 'split nut' to its service position. (Fig 11b)

WARNING: The 'split nut' must be returned to its service position and be fully engaged with the threads on the long vise screw. Pulling back slightly on the vise handle just before the vise jaw contacts the workpiece will help the correct seating of the 'split nut'. Using this machine without the 'split nut' fully engaged with the vise screw threads is dangerous and must not be attempted.

- Tighten the vise to secure the workpiece.
- Check the security of the workpiece before attempting a cut.

(>5.2)

OPERATING INSTRUCTIONS

PREPARING TO MAKE A CUT

Do not overreach. Keep good footing and balance. Stand to one side so that your face and body are out of line of a possible kickback.

Caution: The minimum cut off piece must be 8mm (5/16") or greater in length to avoid the piece falling through the blade slot and causing any potential danger. (Fig 12)

WARNING: Freehand cutting is a major cause of accidents and **should not be attempted.**

- Ensure that the workpiece is firmly secured in the vise.
- The machine's base should be clean and free from any swarf or sawdust etc. before the workpiece is clamped into position.
- Ensure that the 'cut-off' material is free to move sideways away from the blade when the cut is completed. Ensure that the 'cut-off' piece cannot become 'jammed' in any other part of the machine.
- Do not use this saw to cut small pieces. If the workpiece being cut would cause your hand or fingers to be within 150mm of the saw blade, the workpiece is too small.

Angles should be clamped in an inverted position so that the point of the section is uppermost. (<5.2)

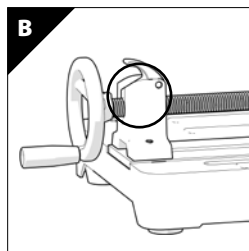
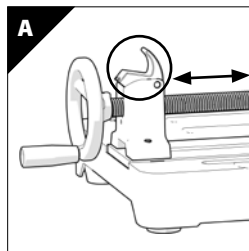

Fig. 11

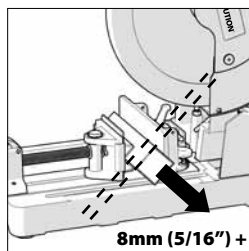

Fig. 12

EN

ES

FR

(5.4)
THE ON/OFF TRIGGER SWITCH

This machine is equipped with a safety start trigger switch.

To start the tool:

- Push in the safety lock button on the side of the handle with your thumb.
- Depress the main trigger switch to start the motor.

WARNING: Never start the saw with the cutting edge of the saw blade in contact with the workpiece surface.

(5.3)
MAKING A CUT

- With the cutting head in the upper position, switch on the motor and allow it to reach full operational speed.
- Gently lower the cutting head.
- Introduce the blade into the material slowly, using light pressure at first to keep the blade from grabbing.
- Gradually increase the pressure as a blade enters the workpiece. Do not 'force' the machine. Let the saw blade do the work.

Note: Cutting performance will not improve by applying undue pressure on the machine, and doing so may cause blade and motor life to be reduced.

- Reduce the pressure as the blade begins to exit the material.
- On completion of a cut allow the cutting head to return to its upper position, and turn off the motor.
- Only remove your hands, or the workpiece from the machine, after the motor has completely stopped and the stationary blade is covered by the lower blade guard.

(6)
MAINTENANCE

(6.1)
Note: Any maintenance must be carried out with the machine switched off and disconnected from the mains/battery power supply.

Check that all safety features and guards are operating correctly on a regular basis. Only use this machine if all guards/safety features are fully operational.

All motor bearings in this machine are lubricated for life. No further lubrication is required.

Use a clean, slightly damp cloth to clean the plastic parts of the machine. Do not use solvents or similar products which could damage the plastic parts.

WARNING: Do not attempt to clean by inserting pointed objects through openings in the machine's casings etc. The machine's air vents should be cleaned using compressed dry air.

Excessive sparking may indicate the presence of dirt in the motor or worn out carbon brushes.

(>6.2)
If this is suspected have the machine serviced and the brushes replaced by a qualified technician with Evolution recommended brushes. **(<6.2)**

CHIP COLLECTION TRAY

The chip collection tray should be emptied at regular intervals. We recommend that for efficiency purposes the tray be emptied when it is approximately 60% full.

To check the Chip Collection Tray:

- Turn the locking lever to the horizontal position and withdraw the tray from the machine to check the contents.
- Empty the contents of the tray into a suitable recycling bin.
- It may be necessary to wear a dust mask when emptying the chip collection tray.
- Replace the chip collection tray and return the locking lever to the vertical position to secure the tray within the machine's base.

(6.4)

ENVIRONMENTAL PROTECTION

Waste electrical products should not be disposed of with household waste. Please recycle where facilities exist. Check with your local authority or retailer for recycling advice.



TRANSPORTATION/STORAGE

For ease and convenience, when transporting or storing the machine, the cutting head can be held in the 'down' position.

To hold the cutting head down:

- Lower the cutting head to its lowest position.
- Rotate the cutting head Locking Pin 1/4 of a turn and allow it to deploy to the 'locked down' position.

EN

ES

FR

EC DECLARATION OF CONFORMITY

In accordance with EN ISO 17050-1:2004

EVOSAW³⁵⁵**The manufacturer of the product covered by this Declaration is:**

Evolution Power Tools, Venture One, Longacre Close, Holbrook Industrial Estate, Sheffield, S20 3FR.

The manufacturer hereby declares that the machine as detailed in this declaration fulfils all the relevant provisions of the Machinery Directive and other appropriate directives as detailed below. The manufacture further declares that the machine as detailed in this declaration, where applicable, fulfils the relevant provisions of the Essential Health and Safety requirements.

The Directives covered by this Declaration are as detailed below:

2006/42/EC.	Machinery Directive.
2004/108/EC.	Electromagnetic Compatibility Directive.
93/68/EC.	The CE Marking Directive.
2011/65/EU.	The Restriction of the Use of certain Hazardous Substances in Electrical Equipment (RoHS) Directive.
2002/96/EC as amended by 2003/108/EC .	The Waste Electrical and Electronic Equipment (WEEE) Directive.

And is in conformity with the applicable requirements of the following documents:

**EN60335-1:1994+A1+A2+A11-A16 • EN60745-2-5:2003 • EN55014-1:2000+A1+A2
EN55014-2:1997+A1 • EN61000-3-2:2000 • EN61000-3-3:1995+A1
EN61000-3-11:2000 • EN60745-1/A1:2003**

Product Details

Description: EVOSAW355 355mm (14") STEEL CUTTING CHOP SAW
Evolution Model No: 080-0001 / 080-0002 / 080-0003 / 080-0006
Brand Name: EVOLUTION
Voltage: 110V / 230V
Input: 50/60Hz

The technical documentation required to demonstrate that the product meets the requirements of directive has been compiled and is available for inspection by the relevant enforcement authorities, and verifies that our technical file contains the documents listed above and that they are the correct standards for the product as detailed above.

Name and address of technical documentation holder.Signed:  Print: Steven Bulloss: Operations Director.Signed:  Print: Lettie Lui: Product Manager.

Date: 29.11.13

EC DECLARATION OF CONFORMITY

In accordance with EN ISO 17050-1:2004



EN

The manufacturer of the product covered by this Declaration is:

Evolution Power Tools, Venture One, Longacre Close, Holbrook Industrial Estate, Sheffield, S20 3FR.

The manufacturer hereby declares that the machine as detailed in this declaration fulfils all the relevant provisions of the Machinery Directive and other appropriate directives as detailed below. The manufacture further declares that the machine as detailed in this declaration, where applicable, fulfils the relevant provisions of the Essential Health and Safety requirements.

The Directives covered by this Declaration are as detailed below:

2006/42/EC.	Machinery Directive.
2004/108/EC.	Electromagnetic Compatibility Directive.
93/68/EC.	The CE Marking Directive.
2011/65/EU.	The Restriction of the Use of certain Hazardous Substances in Electrical Equipment (RoHS) Directive.
2002/96/EC as amended by 2003/108/EC .	The Waste Electrical and Electronic Equipment (WEEE) Directive.

And is in conformity with the applicable requirements of the following documents:

**EN60335-1:1994+A1+A2+A11-A16 • EN60745-2-5:2003 • EN55014-1:2000+A1+A2
EN55014-2:1997+A1 • EN61000-3-2:2000 • EN61000-3-3:1995+A1
EN61000-3-11:2000 • EN60745-1/A1:2003**

ES

Product Details

Description: EVOSAW380 380mm (15") STEEL CUTTING CHOP SAW
 Evolution Model No: 080-0007 / 080-0008 / 080-0009 / 080-0004
 Brand Name: EVOLUTION
 Voltage: 110V / 230V
 Input: 50/60Hz

The technical documentation required to demonstrate that the product meets the requirements of directive has been compiled and is available for inspection by the relevant enforcement authorities, and verifies that our technical file contains the documents listed above and that they are the correct standards for the product as detailed above.

Name and address of technical documentation holder.

Signed:  Print: Steven Bulloss: Operations Director.

Signed:  Print: Lettie Lui: Product Manager.

Date: 29.11.13

FR

evOLUTION®

www.evolutionpowertools.com

UK

Evolution Power Tools Ltd
Venture One
Longacre Close
Holbrook Industrial Estate
Sheffield
S20 3FR

+44 (0)114 251 1022

US

Evolution Power Tools LLC
8363 Research Drive
Davenport
Iowa
52806

+1 866-EVO-TOOL

EU

Evolution Power Tools SAS
61 Avenue Lafontaine
33560
Carbon-Blanc
Bordeaux

+ 33 (0)5 57 30 61 89

Discover Evolution Power Tools

Visit: www.evolutionpowertools.com or download the QR Reader App on your smart phone and scan the QR code (Right).

