

# RAZOR DECK

## Self Erecting Tower (SET) 2M

OPERATION & SAFETY MANUAL



**birchwood**  
products

Control Doc. No. UI 0540/0707/ Issue 04 10/11/08

### THANK YOU FOR BUYING RAZOR DECK

You should read the entire manual before you use Razor Deck, and you should restrict use to persons who have read, understood, and who will follow all warnings and instructions contained in this manual. In addition, you should follow all warnings and instructions fixed to your Razor Deck.

### IMPORTANT SAFETY INSTRUCTIONS

This instruction manual contains vital information for the safe use and efficient operation of the **Razor Deck SET 2M**.

Carefully read and understand all instructions before operating & maintaining the **Razor Deck**. Failure to adhere to the instructions could result in serious personal injury.

If there is anything that you don't understand, **DO NOT** use this equipment. Contact the supplier for advice.

This manual should be used in conjunction with a suitable Risk Assessment and Method Statement (by user) relative to the project to be undertaken.

**Work at Height Regulations 2005, Regulation 6(1).**

It must be noted that all employers have a responsibility to ensure that work methods (practices) and adequate facilities/resources (including work equipment) are provided to eliminate or minimise risks.

**Work at Height Regulations 2005, Regulations 6, 7, 8 and schedule 3 Part 2.**

Only competent personnel should undertake erection & lowering (and organisation, planning and supervision) of the Razor Deck.

### INSPECT YOUR NEW RAZOR DECK

The package should include the following items which should be removed from the packaging carefully and inspected for damage:

1. **RAZOR DECK SET 2M**
2. **OUTRIGGER SUB ASSEMBLIES x4**  
(requires minimal assembly)
3. **USER INSTRUCTIONS**

### INITIAL ASSEMBLY

Upon receiving the Razor Deck SET 2M remove packaging and ensure no damage has occurred in transit.

For protection during shipment the four outrigger and castor assemblies are not fitted to the Razor Deck. Remove these components from the additional packaging and follow the instructions printed on the packaging to assemble them.

These instructions read as follows:

Once unpacked, slide the outrigger casting into the base frame until the fixing holes align.

To ensure the right and left hand outriggers are fitted in the correct position deploy the outrigger. Please note that the outrigger should lock in the following positions; 45°\* & 90°, and will be located on the outside of the Razor Deck for maximum stability.

\*Not all models have both settings.

Insert the 2x M10 x 65mm button head screws (provided) through the holes, ensuring the head of the screw is located on the outside of the base frame.

Using the M10 washer and nyloc nut (provided), secure the outrigger casting to the base frame.

Repeat process for the other 3 outriggers.

**KEEP THIS MANUAL FOR FUTURE REFERENCE.**

**THIS MANUAL MUST BE MADE AVAILABLE TO THE USER/ASSEMBLER AT ALL TIMES.**

## GENERAL SAFETY INFORMATION

1. This manual should be used in conjunction with a suitable Risk Assessment and Method Statement relative to the project to be undertaken.
2. This manual should be used in conjunction with the *WORK AT HEIGHT REGULATIONS 2005* to ensure a safe working environment.
3. A competent person should remain close by whenever the Razor Deck is being used, in case of emergency.

## OPERATOR SAFETY INFORMATION

4. Only competent persons should undertake erection and dismantling.
5. The platform should be used by one person only.
6. When the platform is in use ensure that the access gate is closed and locked, the trapdoor is down and all toeboards are upright.
7. Only gain access to the platform using the described methods as mentioned within this manual and on the unit. Do not climb on or use any other components of the Razor Deck to gain access or to work from.
8. Check all locking components and ensure that Razor Deck is still properly erected each time prior to climbing up to the platform.
9. Never use the Razor Deck if you are unwell, or under the influence of alcohol or drugs.
10. Only use this equipment if you are comfortable with working at height.
11. Check the following items each time before climbing the Razor Deck:
  - The razor deck is still vertical.
  - All locking hinges are fully locked out.
  - The weather conditions have not worsened.
  - All outriggers are deployed correctly.

## PRODUCT SAFETY INFORMATION

12. Ensure that the Razor Deck is thoroughly inspected before use. If any of the components are damaged **DO NOT** use until these faults have been corrected.
13. Ensure the Razor Deck is maintained. Castors and moving components should be lubricated periodically to keep them running freely.
14. Ensure that all necessary components and safety equipment is available and operational.
15. DO NOT add anything to the Razor Deck which would increase its wind loading (ie. notice boards).
16. Maximum Safe Working Load – **150KG (23st 7lb)** – including user, tools & materials.
17. Ensure all labels are present and readable.

## ENVIRONMENTAL SAFETY CONSIDERATIONS

18. Do not use on soft or uneven surfaces. Ensure the ground upon which the Razor Deck is to be used is capable of withstanding the combined weight of the unit and any additional loading.
19. Erect exclusion zone and fit warning signs to comply with *Schedule 3 Part 2 (11), Work at Height Regulations 2005*. Ensure the exclusion zone is a minimum of 1 metre around the Razor Deck.

20. Always beware of live electrical apparatus, cables and moving parts of machinery around the work area.
21. Inform everyone in the work area of what you are doing and to adhere to the exclusion zone.
22. DO NOT use in adverse weather conditions. If the wind is greater than BEAUFORT SCALE 6 (12.5 m/s) do not use the Razor Deck. Consider additional wind loading that could be generated by tunnel effects. Refer to page 4 for further information.
23. Ensure the work area is kept tidy and observe other people within the environment.
24. If positioning against a wall ensure that it would offer adequate protection against the Razor Deck overturning. If positioning Razor Deck against small walls ensure that outriggers are deployed.
25. Please refer to the wind conditions illustrated on page 3.

## TRANSPORTATION SAFETY INFORMATION

26. Razor Deck can be moved manually, by pushing from the base.
27. Always inspect the Razor Deck after moving it and before use.
28. Ensure that the Razor Deck is unmanned and free of equipment and that brake locks are off prior to movement. Beware of soft or uneven ground and overhead obstructions.
29. Razor Deck weighs 82Kg. Caution should be observed when lifting and moving.
30. When lifting the Razor Deck ensure that the unit is lowered.
31. If lifting the Razor Deck ensure that the unit is lifted from the lifting points labelled on the unit.

## WORKING PRACTICES SAFETY INFORMATION

32. When lifting components or materials, always lift from within the Razor Deck base where possible.
33. Never bridge between Razor Deck and another building/structure.
34. Do not use hoisting apparatus on Razor Deck.
35. Care should be taken when using power tools, wash jets or other tools that cause lateral force. The maximum lateral force on Razor Deck at platform level is 45kg.
36. Temporary means of gaining additional height e.g. steps or trestles **MUST NOT** be used on the Razor Deck. Do not stand on guard wires, toeboards or the handrail.
37. Ensure your centre of gravity remains within the Razor Deck. **DO NOT OVERREACH.**
38. Only carry tools and materials with you when ascending/descending the Razor Deck if they are safely retained in a tool belt and do not restrict movement.
39. DO NOT leave the tower unattended.
40. Deploy outriggers during use.
41. Do not use the Razor Deck whilst unit is suspended or lifted.

## RISK ASSESSMENT

It is the user's responsibility to carry out a full Risk Assessment before using the Razor Deck. The Risk Assessment should establish a safe working zone and practices to ensure their safety.

## PERSONAL PROTECTIVE EQUIPMENT

Ensure the operator is wearing the correct personal protective equipment for the task to be undertaken. Gloves should be worn when lifting or manouvering the Razor Deck. Where appropriate, wear a hard hat and suitable clothing.

## LIFTING

Whenever possible lift the razor deck using either a tail lift or forklift depending on ground conditions and purpose of the move.

Ensure the forks are located under the main base frame, please note the label located on the inside of the base frame to illustrate these lifting points.

If required to manually lift please note the unit weights 82 Kg. Ensure all persons involved in the lift are physically capable of such a lift and familiar with the lifting points – **DO NOT** use the outriggers to lift the razor deck.

Ensure the transit lock is in the locked position and all brakes on the castors are applied.

## MOVING

If you intend to move the razor deck over a short distance (less than 50 metres)

Considerations before moving.

Ensure the ground along the intended route is clear of any obstacles. Consider any size limitations/restrictions along the route at both ground level and at the fully extended height (3 metres). Ensure the ground is level and suitable to transit the razor deck.

If you wish to move the Razor Deck to another location:

1. Clear platform of all tools, materials and personnel.
2. Raise 4x outriggers, locking them approximately 25 mm from ground.
3. Release 4x castor brakes.
4. Carefully move tower.
5. Once in position – lock castors, reset outriggers and continue to work.

NB. To move the unit over great distance (>50 metres) or uneven ground, fully lower it before moving. Again consider any restrictions/limitations along the route.

## STORAGE

When not being used, store the unit in a clean condition and in a safe place away from thieves and unauthorised users.

If the unit is intended to be stored for a period of 1 month or more ensure the unit is fully cleaned and lubricated before storing. Attach a label to the unit specifying the date when the unit was stored.

Upon taking any unit form storage ensure a full inspection is conducted and all lubrication procedures Are carried out if required.

## MAINTENANCE PROCEDURE

### Pre-use functionality checks.

- Security and functionality of castors and brakes.
- Function and secure locking of all elbow joints and triggers.
- Function and operation of the outriggers including self-locking plunger. Ensure all preset increments can be engaged and fully lock.
- Function and operation of the transit lock lever.
- Function and operation of the hand rail system.
- Function and operation of the sprung end toe boards.
- Function and operation of the dagger lock on the access section of the razor deck.
- Function and operation of the hinged access trapdoor.
- Ensure the gate locking catch mechanism is functional and self-locking.

### Pre-use visual checks.

- All aluminium sections and sub assemblies for fatigue or damage.
- Inspect all welded parts for any signs of damage or fatigue.
- Inspect external spring set for signs of fatigue or damage.
- Inspect the flexible handrail cables for fatigue and damage, ensure the eyelets are secured to the handrail uprights.
- Inspect the deck boards for splitting, cracks or delaminating.
- Inspect all toe boards for fatigue or damage.
- Inspect all visible nut and bolt fixings.
- Ensure all rubber feet bungs are present within the adjustable sections of the outriggers.
- Ensure all the warning and instruction labels are present and clearly legible.

**Lubrication.**

- Lubricate all elbow locks and triggers on a monthly basis.
- Lubricate the outrigger adjustment tube on a monthly basis.
- Lubricate the castor wheels every six months or when required
- Lubricate the dagger lock located on the access section on a monthly basis.
- Lubricate the gate locking catch mechanism on a monthly basis.
- Lubricate and remove any debris that has collected around the hinged springs on the end toe-boards.

**Damage reporting.**

If any damaged is found **DO NOT** use the product. Clearly label the razor deck including the fault identified. Notify your supervisor or contact the hirer/retailer and arrange for the fault to be rectified.

Ensure either the manufacturer carries out work or their representative to ensure validity of the razor decks warranty.  
Upon completion of any work ensure a thorough inspection is conducted after.

**Inspection frequency.**

Ensure the razor deck is fully inspected every seven days by a competent person. This is the responsibility of the user or hirer unless otherwise agreed with the hire company.

Inspection report must be completed by the end of the shift and submitted to the supervisor within 24 hrs.

Reports to be kept on site until the job is finished and at the company's office for three months after the job has finished.

**WIND CONSIDERATIONS.**

No.	Knots	mph	Description	Effects on land
0	0	0mph	Calm	Smoke rises vertically.
1	1-3	1-3mph	Light air.	Smoke drifts in the wind.
2	4-6	4-7mph	Light breeze.	Leaves rustle. Wind felt on face.
3	7-10	8-12mph	Gentle breeze.	Small twigs in constant motion. Light flags extended.
4	11-16	13-18mph	Moderate wind.	Dust, leaves and loose paper raised. Small branches move
5	17-21	19-24mph	Fresh wind.	Small trees sway.
6	22-27	25-31mph	Strong wind.	Large branches move. Whistling in phone wires. Difficult to use umbrellas.
7	28-33	32-38mph	Very strong wind.	Whole trees in motion.
8	34-40	39-46mph	Gale.	Twigs break off trees. Difficult to walk.
9	41-47	47-54mph	Severe gale.	Chimney pots and slates removed.
10	48-55	55-63mph	Storm.	Trees uprooted. Structural damage.
11	56-63	64-72mph	Severe storm.	Widespread damage.
12	63	73mph	Hurricane force.	Widespread damage. Very rarely experienced on land.

# RAZOR DECK TERMS OF DEFINITION

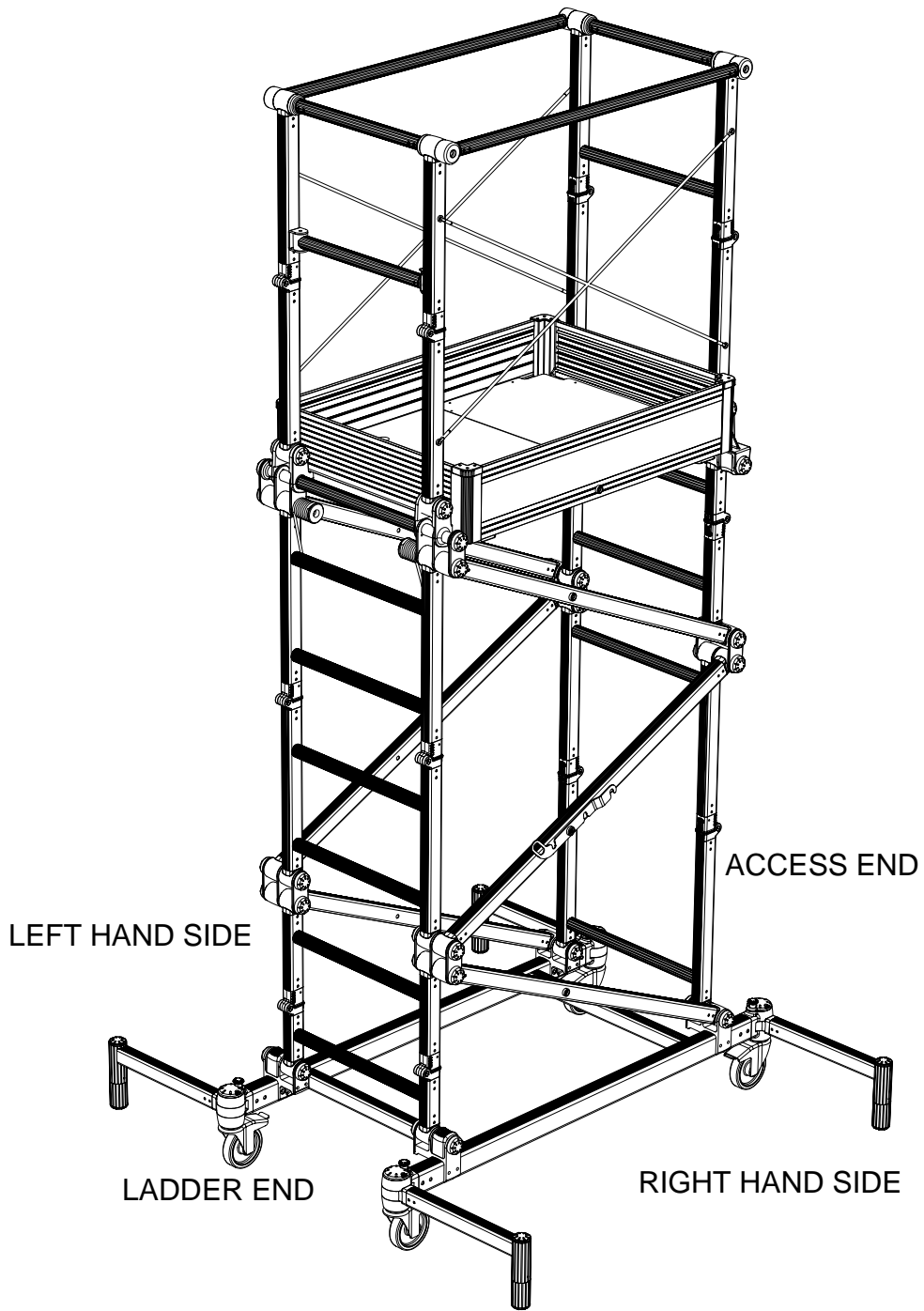

## RAZOR DECK IDENTIFICATION

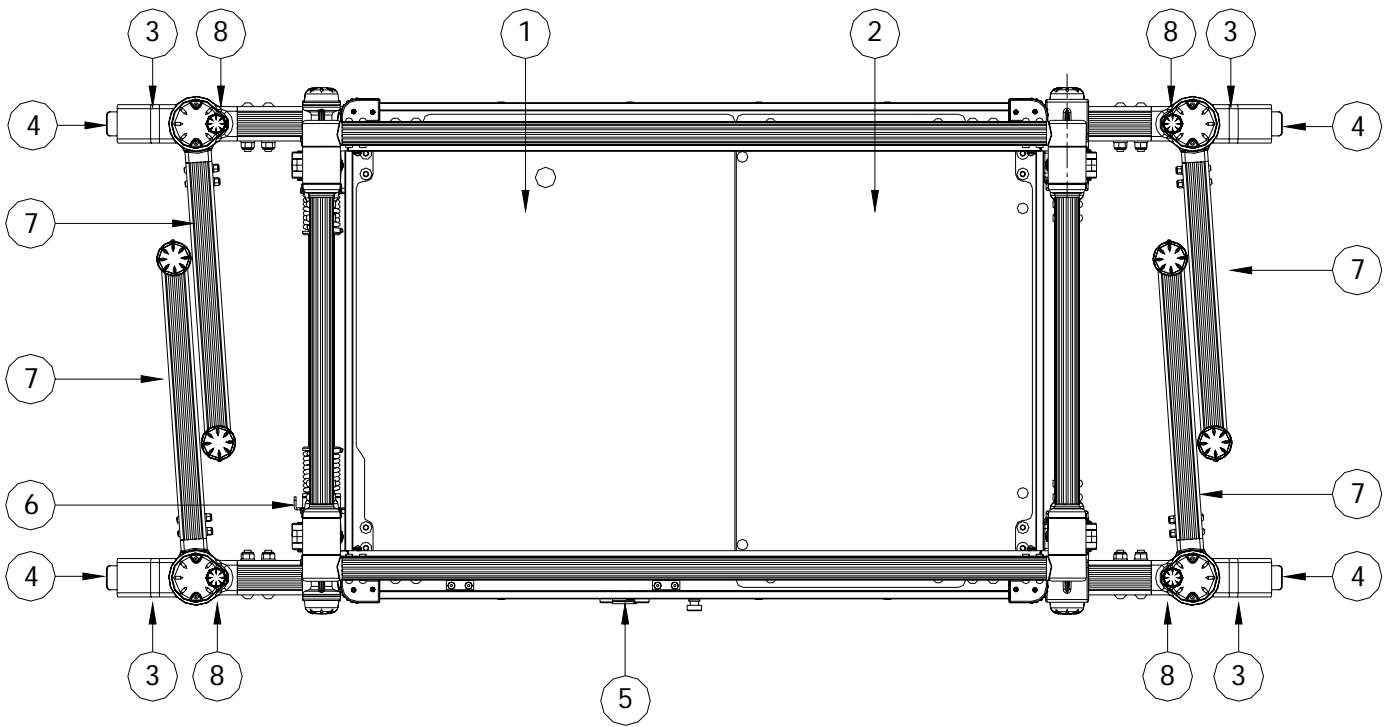

1. Access trapdoor/ hinged platform
2. Fixed platform
3. Castor
4. Castor wheel and swivel lock
5. Transit deck lock lever
6. Tilt latch
7. Outrigger
8. Outrigger locking plunger

## RAZOR DECK IDENTIFICATION

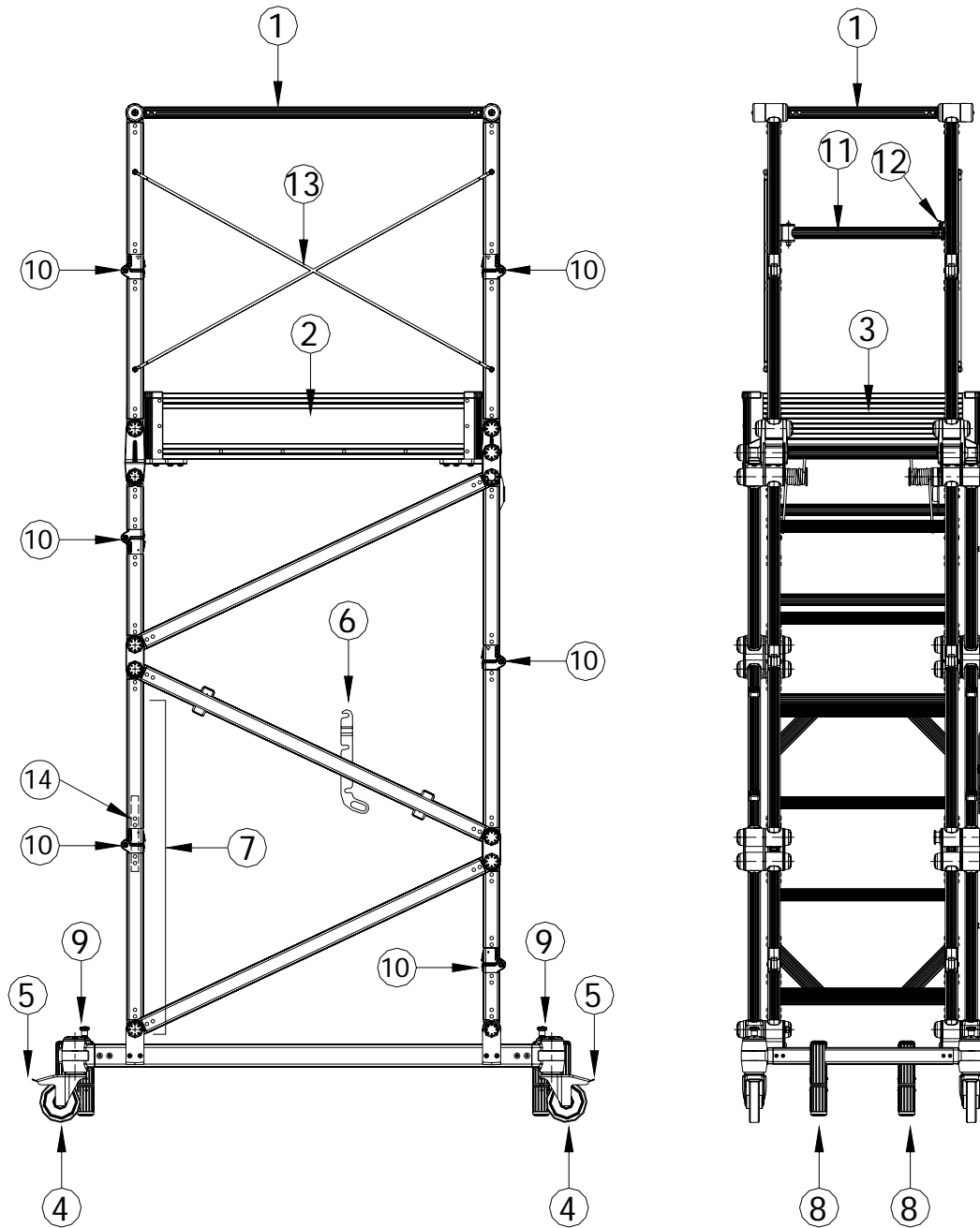

1. Handrail
2. Side fixed toe board
3. Hinged end toe board
4. Castors
5. Castor wheel and swivel lock
6. Transit deck lock lever
7. Access section (2M setting only)
8. Outriggers – variable height adjustment
9. Outrigger locking plunger
10. Locking elbow hinge
11. Lower level access gate
12. Access gate lock mechanism
13. Wire guard rail
14. Dagger Lock

# RAZOR DECK LABEL LOCATION

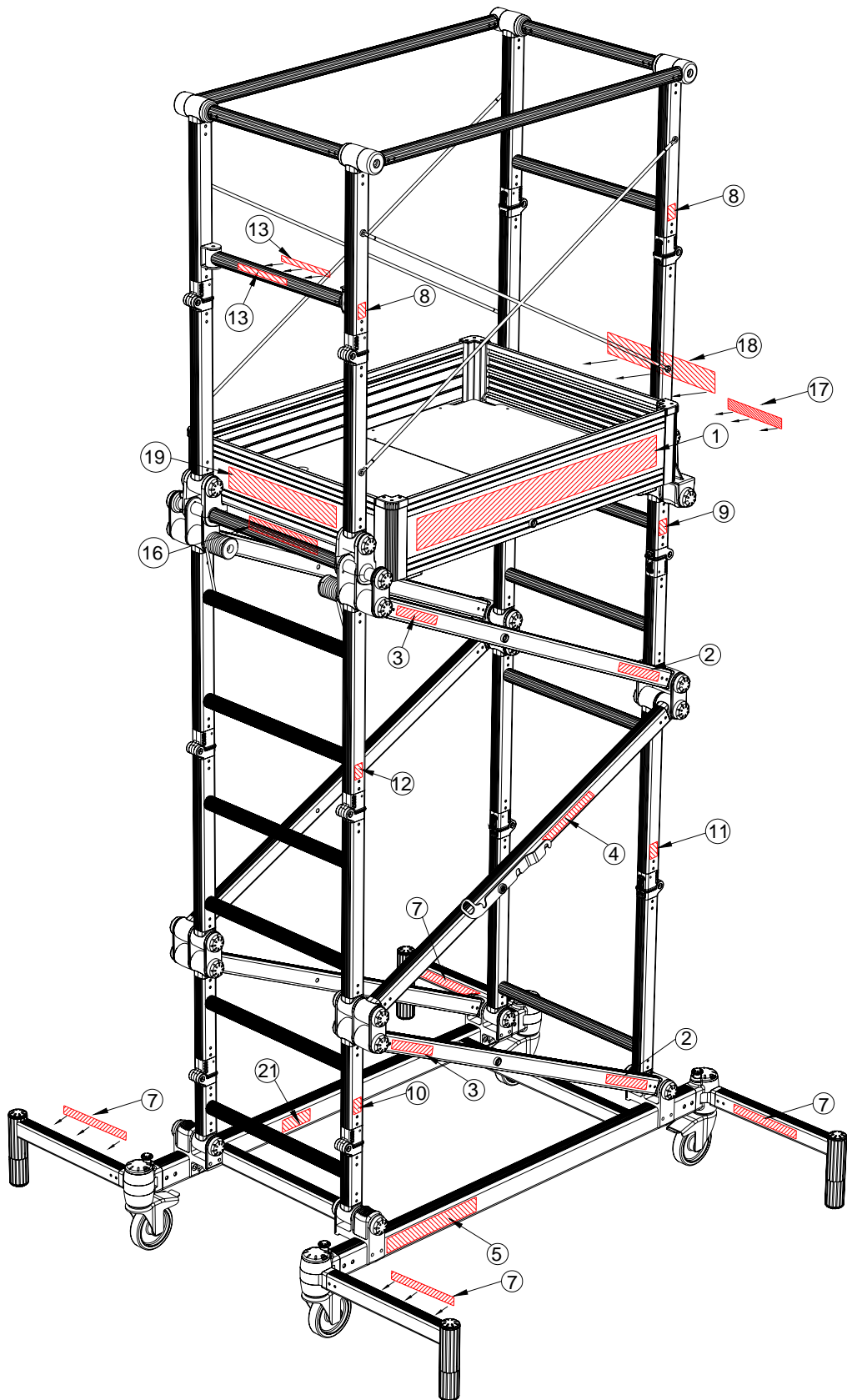



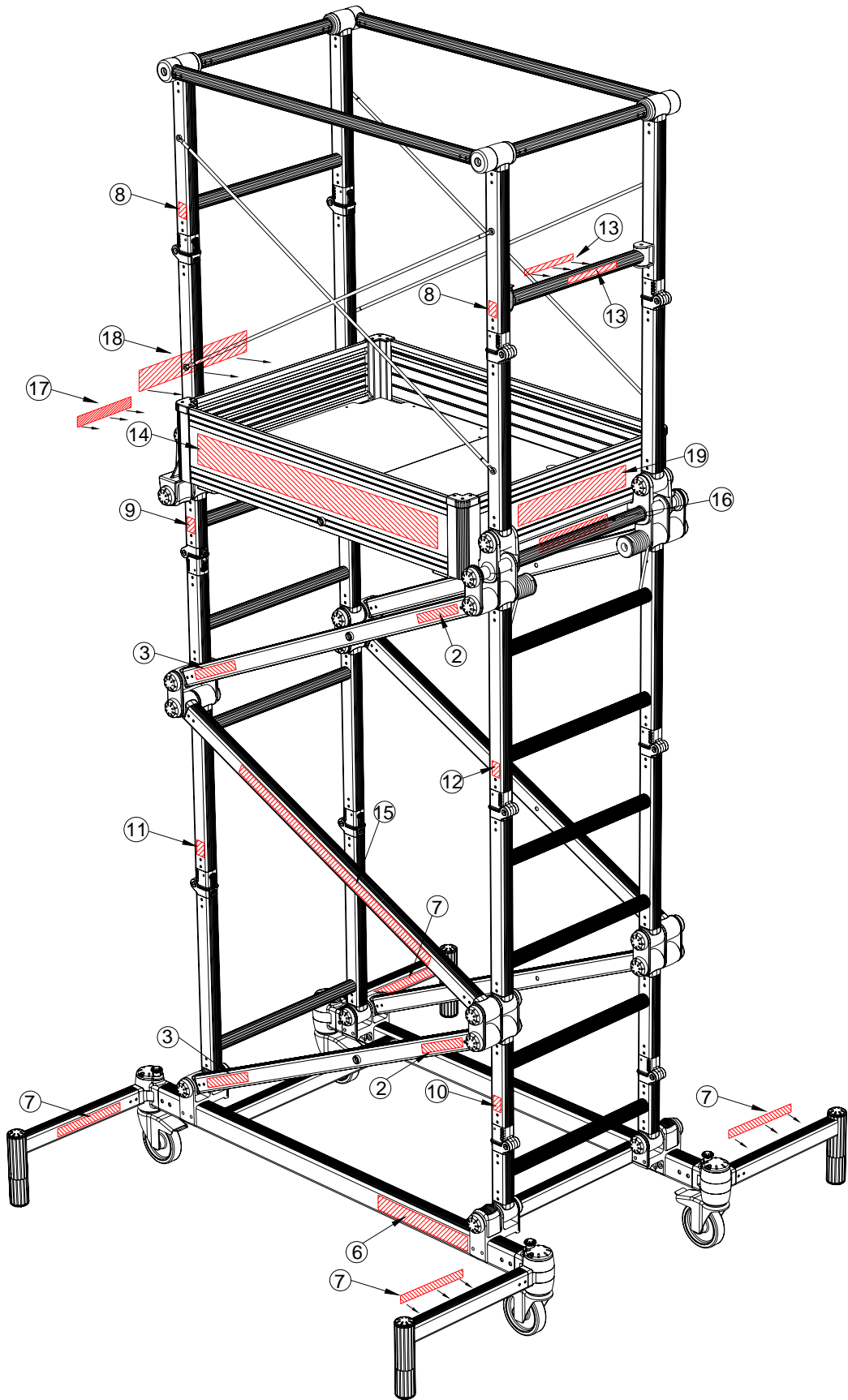

**Label 1** - Safety Instructions caution label X1. Located on LHS on toe-board platform. 678mm x 80mm black/red on yellow self- adhesive.

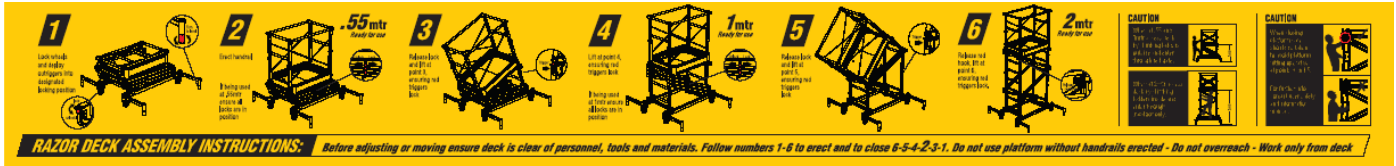

**Label 2** - Caution Trap Hazard screen-printed on the diagonal braces X4. “Caution” printed in black with warning triangle. “Trap Hazard” screen-printed in red.



Quantity 4  
size: 111 x 40mm

**Label 3** - Caution Trap Hazard screen-printed on the diagonal braces X4. “Caution” printed in black with warning triangle. “Trap Hazard” screen-printed in red.



Quantity 4  
size: 111 x 31mm

**Label 4** - screen-printed onto middle diagonal brace on lock side of razor deck X1.

**Engage lock when in transportation**

Quantity 1  
size: 155 x 10mm

**Label 5** - Graduated chevron black on clear self-adhesive label 494 x 41mm X1. Chevron runs dark to light from left to right.



Quantity 1  
size: 494 x 41mm

**Label 6** - Graduated chevron black on clear self-adhesive label 494 x 41mm X1. Chevron runs dark to light from right to left.



Quantity 1  
size: 494 x 41mm

**Label 7** - Outrigger Branding – Located on the outside of all four outriggers. Screen-printed directly onto the outrigger X4.

Left Outrigger

**Lock castors and deploy stabilisers before use  
turn red drum to level - Do not lift by stabilisers**

**1**

Right Outrigger

**1**

**Lock castors and deploy stabilisers before use  
turn red drum to level - Do not lift by stabilisers**

The number “1” must be located next to the outrigger adjustment plunger knob.

**Label 8** - Sequential erection/disassembly numbers. Each section of the Razor Deck is number to ensure correct operation of the unit. Each number is screen printed black directly onto aluminum frames 13 x 30 mm. Handrail sections.

**2**

Quantity 2  
size: 20 x 30mm

**Label 9 - Sequential erection/disassembly numbers. Each section of the Razor Deck is number to ensure correct operation of the unit. Each number is screen printed black directly onto aluminum frames 13 x 30 mm. Small access section.**

# 3

Quantity 2  
size: 19 x 31mm

**Label 10 - Sequential erection/disassembly numbers. Each section of the Razor Deck is number to ensure correct operation of the unit. Each number is screen printed black directly onto aluminum frames 13 x 30 mm. Small ladder section.**

# 4

Quantity 2  
size: 19 x 31mm

**Label 11 - Sequential erection/disassembly numbers. Each section of the Razor Deck is number to ensure correct operation of the unit. Each number is screen printed black directly onto aluminum frames 13 x 30 mm. Large access section.**

# 5

Quantity 2  
size: 19 x 31mm

**Label 12** - Sequential erection/disassembly numbers. Each section of the Razor Deck is number to ensure correct operation of the unit. Each number is screen printed black directly onto aluminum frames 13 x 30 mm. Large ladder section.

# 6

Quantity 4 - PRINT ON CLEAR LABEL  
size: 19 x 31mm

**Label 13** - Close and Lock gate label 180mm x 13mm located on the front & rear of the top horizontal section of the gate X2. Black on clear self-adhesive.

## Close and lock gate when in use

Quantity 1  
size: 180 x 13mm

**Label 14** - Branding artwork. Located on RHS on toe-board platform. 678 mm x 80 mm black screen-printed X1.



**Label 15** - Graduated chevron black on clear self-adhesive with self-erecting tower text in the centre of label 1070 x 37mm X1. Chevron runs dark to light from outside to inside.



**Label 16** - "Caution when extended to 2 metres access deck by trap door only. Climb ladder internally." Black on yellow vinyl self adhesive label 192 x31 mm X1. Located beneath the folding toe board on the ladder side of the Razor deck.



Quantity 1  
size: 192 x 31mm

**Label 17 - Caution – various operator instructions. Black on yellow vinyl self-adhesive label 192 x31 mm X1. Located beneath the folding toe board on the access side of the Razor deck.**



Quantity 1  
size: 192 x 31mm

**Label 18 - Caution – various operator instructions. Black screen-printed label 192 x31 mm X1. Located on the folding toe board on the access side of the Razor deck.**



**Label 19 - Caution – various operator instructions. Black screen-printed label 192 x31 mm X1. Located on the folding toe board on the ladder side of the Razor deck.**



**Label 20 - Caution – various operator instructions. Black on yellow vinyl self-adhesive label 192 x31 mm X1. Located on the underneath of the hinged trapdoor.**



Quantity 1 - LABEL  
size: 150 x 106mm

**Label 21 - Rating Label – Located on the inside of the base frame.**

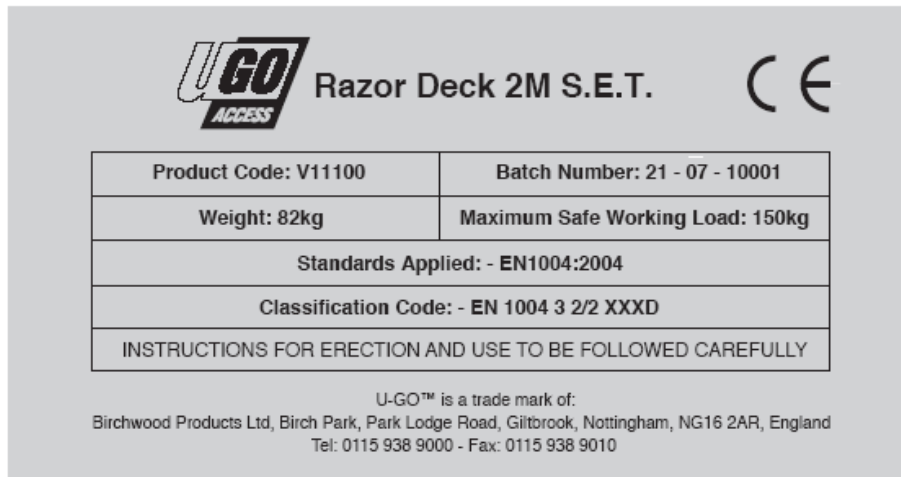

1x Silver vinyl label black text size: 95 x 50mm

## GENERAL OPERATIONAL INFORMATION

Make sure you are aware of all safety requirements and that this equipment is suitable for the task you wish to undertake. Ensure a Risk Assessment has been conducted and a method statement drafted.

The work area must be cordoned off from the general public and bystanders.

A minimum 1 metre exclusion zone is required.

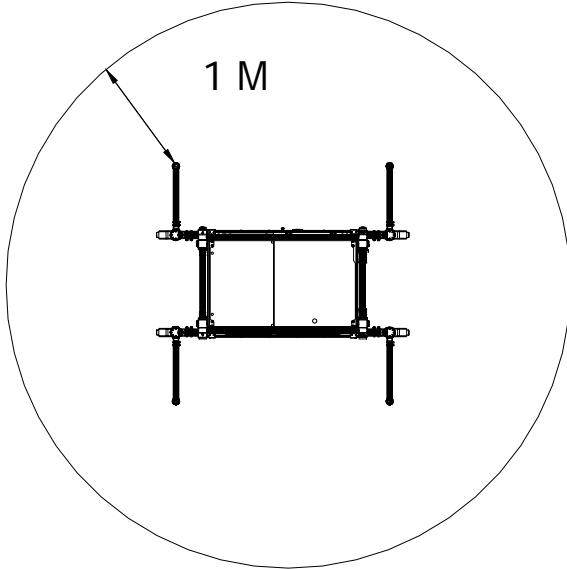

Ensure that the work area is clean and tidy.

Wear the correct Personal Protective Equipment for the task ahead.

Inform everyone in the work area of what you are doing.

### ERECTING THE RAZOR DECK

The 'process numbers' shown correspond to the appropriate numbers on the Razor Deck itself. Each number represents a separate process:

#### Process 1: SECURING THE UNIT

- 1i Wheel unit into position where work is to be done. Allow a minimum 2 metre end clearance for the platform overhang that occurs when erecting to the 2 metre platform height.
- 1ii Lock all 4 castors.

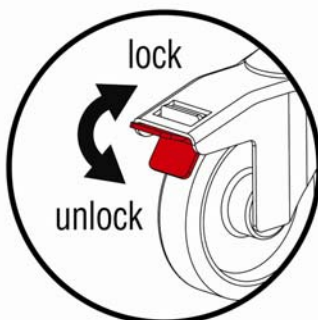

- 1iii Deploy all 4 outriggers one at a time (labelled '1'), removing outrigger locking plunger and turning outrigger assembly outward – ideally to 90 degrees to maximise stability (see page 9 for setting options). Reinsert outrigger locking plunger to hold assembly in position.

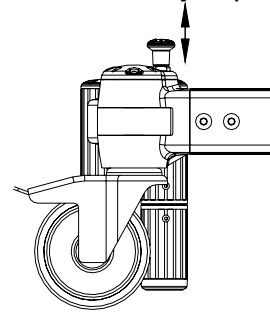

- 1iv Adjust outrigger variable height adjuster to ensure maximum contact with ground.



- 1v Ensure transit deck lock lever is in locked position.



#### Process 2: ASSEMBLING THE HANDRAIL AND RAISING THE PLATFORM TO HEIGHT 1 AT 0.55 METRE

- 2i Lift and pull the 2x locking elbow hinges of handrail set (labelled '2') off the platform towards you at 'access' end until securely locked in place. Repeat at 'ladder' end to form a complete sturdy handrail.
- 2ii Double check that transit deck lock lever is in locked position.
- 2iii If the trigger (red) has not fully returned past the lock housing do not use. Apply a small force to the latch side of the lock until the spring forces the trigger to lock fully (as illustrated). If the hinges will not lock fully DO NOT use and contact the supplier.



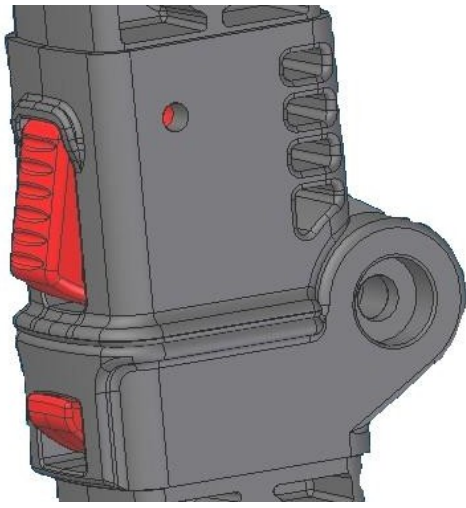

**Unit is now ready for use at 0.55 metre platform height.**

- 2iv Access platform through lower level access gate by unlocking and opening access gate lock mechanism.
- 2v Put leading foot onto platform. Note that hinged toe board folds down to allow for easy access. Lower head and step through gap onto platform, pulling yourself up by grasping outer top handrails.
- 2vi Lock gate immediately once on platform.

**Processes 3. & 4: RAISING PLATFORM TO HEIGHT 2 AT 1.0 METRE**

- 3i Release transit deck lock lever.
- 3ii Standing at 'access' end lift first bar located below platform (labelled '3') to open until the locking elbow hinge's latch and fully lock out the section. Platform is now at an angle.
- 4i Move to 'ladder end' and lift yellow bar (adjacent to side bar labelled '4') to open until the locking elbow hinge's latch and fully lock out. Platform is now level.
- 4ii Lock the transit deck lock lever.
- 4iii Climb integral ladder from the outside and access as per 2v. Lock gate immediately once on platform.

**Unit is now ready for use at 1.0 metre platform height.**

**Process 5: RAISING PLATFORM TO HEIGHT 3 AT 2.0 METRES**

- 5i Release transit deck lock lever.
- 5ii At 'access end' raise bar (adjacent to side bar labelled '5') to open until the locking elbow hinge's latch and fully lock out.
- 6i Move to 'ladder end' and unlock tilt latch. Press and hold lock in position during start of lifting sequence.
- 6ii At 'ladder end' lift yellow bar (adjacent to side bar labelled '6') to open until the locking elbow

hinges engage and secure the section in position.

- 6iii Make sure ladder is vertical and all hinged elbow locks are engaged.
- 6iv The Razor Deck is fitted with an additional lock (dagger lock) on the access section joint for safety. This lock will self latch during assembly.
- 6v Move back to 'access' to climb inside tower structure.
- 6vi Mount integral ladder and enter platform through access trap door by lifting it.
- 6vii Close access trap door firmly.

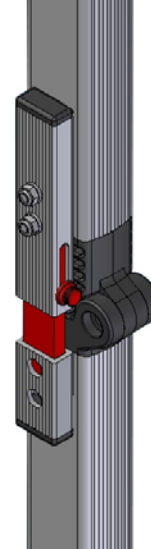

**Unit is now ready for use at 2.0 metre platform height.**

**MOVING THE RAZOR DECK**

If you wish to move the Razor Deck to another location:

1. Clear platform of all tools, materials and personnel.
2. Raise 4x outriggers, locking them approximately 25mm from ground.
3. Release 4x castor brakes.
4. Carefully move tower.
5. Once in position – lock castors, reset outriggers and visually inspect all locking hinge sections.

NB. To move the unit over great distance (>50 metres) or uneven ground, fully lower it before moving.

**LOWERING THE RAZOR DECK**

Lowering the unit is the complete reverse of erection. Please note the following points to ensure that no personal injury occurs:

1. Before lowering the unit ensure that all castors are locked.
2. Locking elbow hinges have to be released at each stage to lower the unit. To release elbow hinge, squeeze in trigger and push elbow away to break it hinge.

3. Ensure the hinge is just disengaged, do not fold the section completely unless the platform weight is supported.

**ENSURE THAT WEIGHT OF PLATFORM IS SUPPORTED WITH ONE HAND BEFORE FOLDING THE FRAME. KEEP HEAD AND CHEST CLEAR OF PLATFORM AS IT DESCENDS.**

4. To release the dagger lock on the 'access' section of the Razor Deck lift the locking bar up before depressing the red trigger, then open the hinge.
5. Lower platform slowly and with care.
6. Re-engage the transit deck lock lever.
7. Fold down the hand rails and stow the outriggers, ensuring that the variable height adjusters are engaged to hold them in position.

**EQUIPMENT MAINTENANCE & CLEANING**

When not being used, store the unit in a clean condition and in a safe place away from thieves and unauthorised users.

**OUTRIGGER POSITIONING**

If placing your Razor Deck in the middle of a work area you are advised to deploy the outriggers at either 45°\* or 90°.

\*Not all models have the 45° setting.

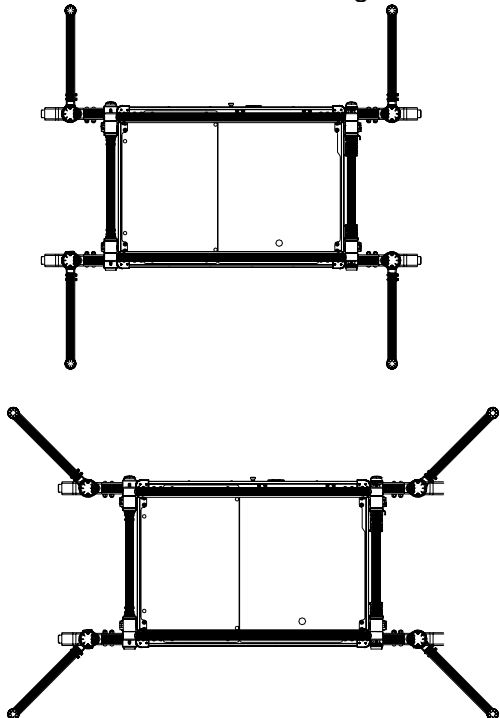

If the Razor Deck is to be used in a narrow high-sided aisle no outriggers are required.

If positioning Razor Deck against a wall the 2 outriggers closest the wall will not require deploying, as long as the wall offers adequate protection against overturning. Against low walls the outriggers should be deployed at either 45° or 90°.

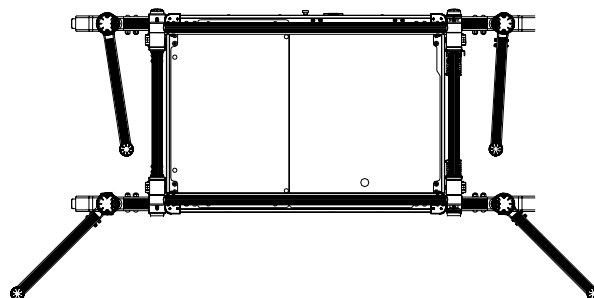
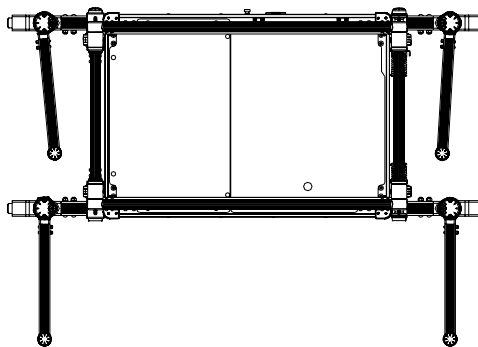

Each application will require an individual Risk Assessment. Ensure the work to be undertaken is considered. Where force is likely to be applied, deploy outriggers accordingly. Ensure the red adjustable section of the outrigger is firmly in contact with the ground.

**SPECIFICATION DATA**

<b>PART NUMBER</b>	V11100
<b>PRODUCT DESCRIPTION</b>	RAZOR DECK SET 2M
<b>WEIGHT</b>	82KG
<b>DIMENSIONS (LxWxH)</b>	1711 x 770 x 890 mm Stowed 1711 x 770 x 3096 mm Erected
	The sound pressure level at the operator's position does not exceed 70 dB (A)

Birchwood Products  
 Birch Park  
 Park Lodge Road  
 Giltbrook  
 Nottingham  
 NG16 2AR  
 Tel: +44 (0)115 938 9000  
 Fax: +44 (0)115 938 9010  
 e-mail: sales@birchwoodproducts.com  
 Website: [www.birchwood-products.co.uk](http://www.birchwood-products.co.uk)

Instruction Manual EN 1298 - IM - en