

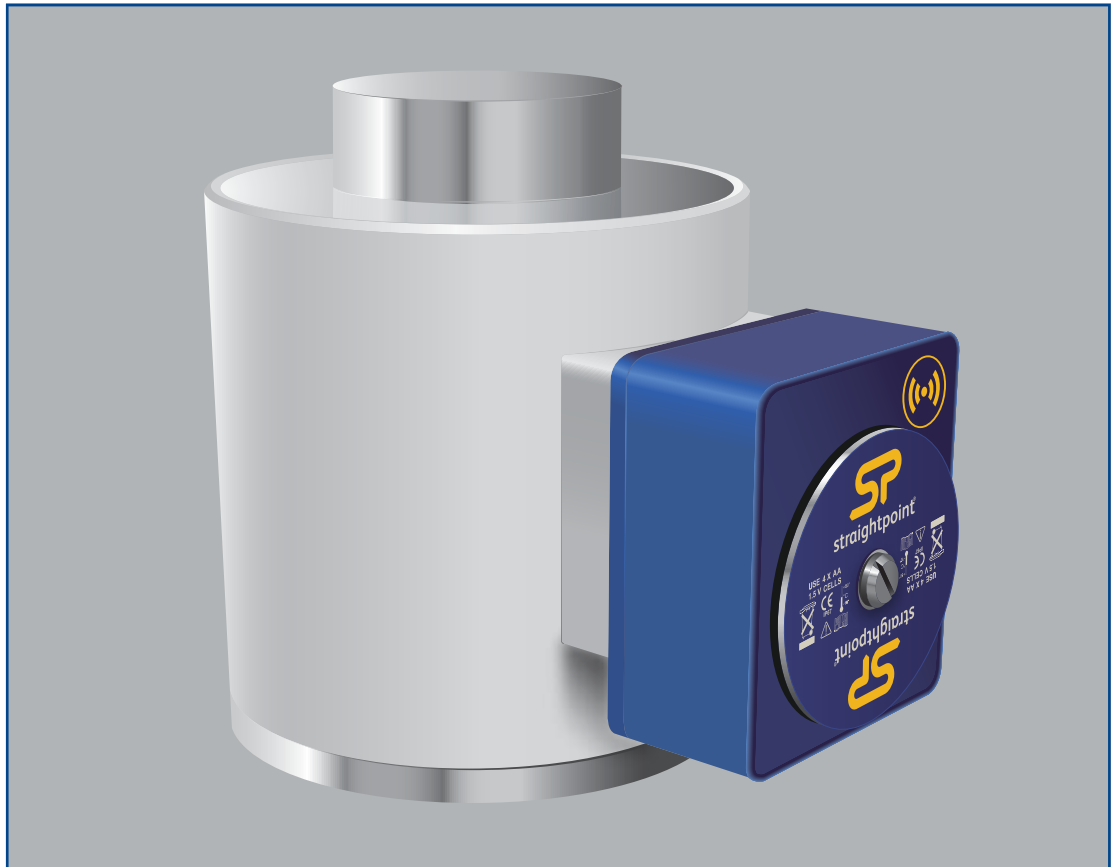

wireless compression load cell



Taking the heavy lift and structural weighing industry by storm is the Straightpoint Wireless compression load cell. By adding the Straightpoint wireless system to the already popular compression load cell line we have developed a cost-effective alternative to standard compression load cells.

No longer hindered by troublesome and hard to maintain cables, large scale projects can be completed in a fraction of time previously required. Maintenance costs are all but eliminated due to the absence of cables and connectors, and the product's flexibility opens the door to a large number of applications in the mining, energy, defence, heavy rigging, shipping, and general transportation sectors, previously not considered.

Straightpoint's Wireless compression load cells are machined from high grade stainless steel, providing excellent strength and corrosion resistance. The heavy duty, compact load cell utilises Straightpoint's advanced microprocessor based electronics and benefits from unrivalled resolution and accuracy. Data transmission is handled by the Straightpoint Wireless System's proprietary transport protocol and is unmatched in performance, capable of a license free transmission range of up to 250 metres.

It is not until you add the powerful array of wireless accessories that the full potential of this product is realised. These accessories which include a wireless signal booster and several user friendly windows based software packages, provide a level of flexibility not previously known in the load monitoring industry. The system's creative software solutions allow for the calculation of centre of gravity, the ability to data log and print reports, and allow the simultaneous display and monitoring of up to 24 wireless load cells on a single PC screen.

Features and benefits:

- Proprietary 2.4 GHz Wireless
- Industry Leading Wireless Range
- Error Free Data Transmission
- Internal Antennae
- Advanced Options Available
- No Cable Assemblies
- Unrivalled Resolution
- Audible Overload Alarm
- Unmatched Battery Life
- Reduced Maintenance Cost
- Compact Size
- Remote On-Off

metric specifications

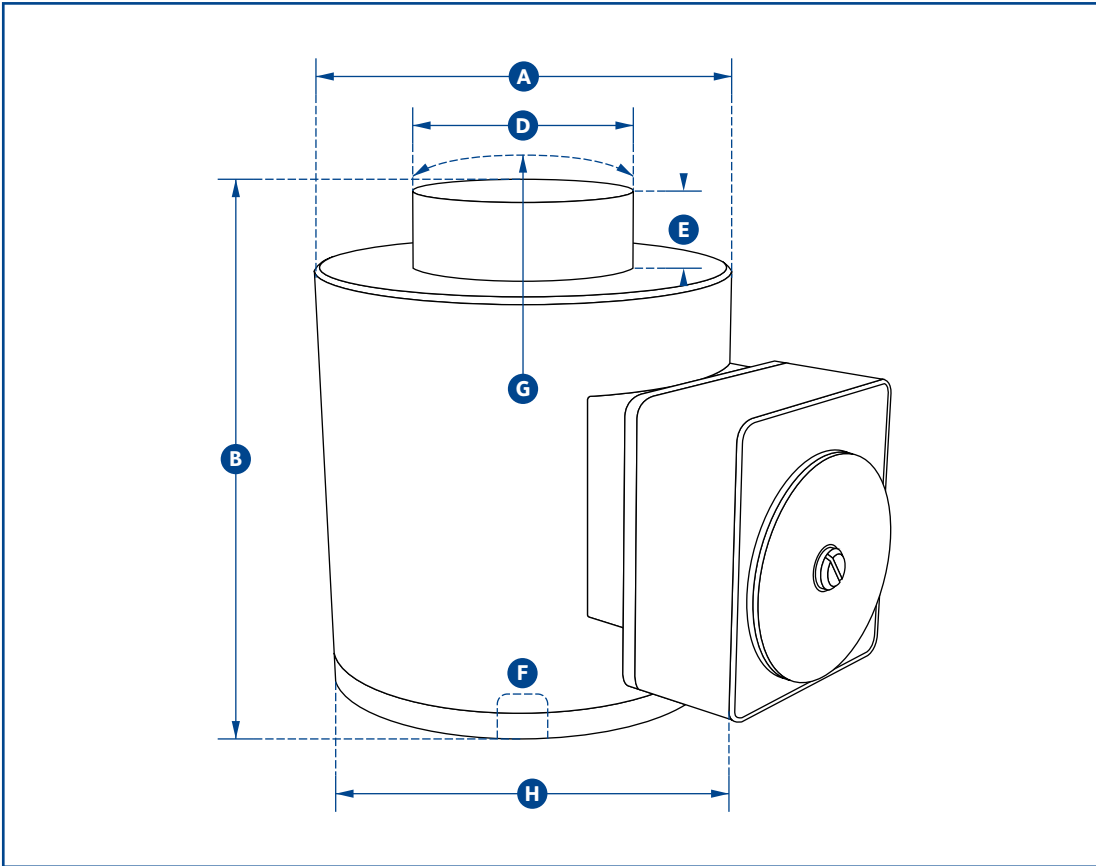

wireless compression load cell

Part Number	WNI50TC	WNI100TC	WNI150TC	WNI300TC	WNI500TC
Capacity	50te	100te	150te	300te	500te
Resolution	0.02te	0.1te	0.1te	0.1te	0.5te
Units	tonne				
Weight	6.2kg	15.5kg	15.5kg	65kg	65kg
Safety Factor	3:1				
Battery Type	Load cell 4 x AA Alkaline				
Battery Life	Load cell 1200hrs continuous				
Operating Temp	-10 to +50°C				
Accuracy	± 0.3% of applied load				
Frequency	2.4Ghz				
System Range	250 metres				
Data Rate	3Hz (configurable to 200Hz)				
Protection	IP67				
Dimension A	102	152	152	185	185
Dimension B	127	184	184	300	300
Dimension D	59	80	80	155	155
Dimension E	13	26	26	27.5	27.5
Dimension F	M20 x 2.5	M20 x 2.5	M20 x 2.5	M20 x 2.5	M20 x 2.5
Dimension G	152	432	432	432	432
Dimension H	158	208	208	241	241

Capacities from 500t - 2000t (price on application).